

EC5300R**Digital Indicating Controller****OUTLINE**

Model EC5300R Digital Indicating Controller has a large-sized display excellent in visibility. Since it is a light guide system, it is clear also outdoors. And dial setting is fulfilled easy operation. In addition, self-tuning is equipped as a standard. PID, gapped PID or heat/cool control are available as control functions. As described above, the EC5300R 1/8DIN controller is applicable to a broad use.

FEATURES

- Extra-large digital display
- Auto-Tuning, Self-Tuning provided as standard
- Full Multi-Input (Thermocouple, RTD, voltage or current)
- Scaling Range of -1999 to 9999
- Multi- Output (Selective)
- 4 Alarm Output
- RS-232C, RS-422A (RS-485) Communication Interface
- Easy Replace from EC5300S

**SPECIFICATIONS**

Input range: Full multi-range, refer to Range table

Display: 7-segment LED, process variable(PV)/ green, set point(SP) & output/ orange

Sampling Rate: 250ms

Scaling: -1999 to 9999 with mV, V & mA ranges

Set point: Front panel (local) or remote (optional)

Set point bias: $\pm 20\%$ available with remote set point

Set point tracking: Remote to local

Set point limiter: 0 ~ 100% with TC & RTD input ranges

Multi set point: Up to 8 set points

Sensor correction: $\pm 100^\circ\text{C}$ with TC & RTD input ranges

Set point ramping: 0.01 ~ 650.0 unit/min. Unit $^\circ\text{C}$ or %

Control: PID, gapped PID, PD, 3-position (dual output) or ON/OFF

Proportional band: 0.1~999.9%

Integral (reset): 0.01 ~99.99 min.

Derivative (rate): 0~20.00 min.

Manual reset: 0~100%, PD control mode only

Dead band: $\pm (0\sim 0.500)$, heat/cool control mode

Hysteresis: 0.00~20.00%, ON/OFF control mode

PID adjustment: Independent on each set point

Programmed PID: 8 PID parameters can be selected automatically to optional remote set point

PID tuning: Selectable Auto tuning or Self tuning

Output: Selectable output from among

Relay; a-contact, 250VAC, 3A resistive load

SSR Drive; 15VDC, 20mA max.

Current; 4~20mA/600 Ω or 0~5mA/2k Ω

Dual output: Any combination from among relay, SSR drive and current output

Auto/Manual: Balance less bump less transfer

Output limiter: 0 ~ 100%

Direct/Reverse: Selectable, reverse in Dual output model

Cycle time: 1 ~ 120 sec., relay and SSR drive output

RUN/STOP: Controller enable/disabled

Preset manual: 0 ~ 100%, available when controller disabled

Alarm: 4 set point process variable or deviation alarm

Alarm set point: Process variable alarm, 0 ~ 100% of range, deviation alarm, $\pm 100\%$ of range

Hysteresis: 0 ~ 100% adjustable within the range

Alarm on delay timer: 0 ~ 600 sec.

Nos. of output relays: 4 relays, driven from among each alarm and controller status(2 relays are optional)

Relay rating: a-contact, 250VAC 0.5A, resistive load, One side contact are common.

Status Output: AUTO/MAN, RUN/STOP, Watchdog timer & Reach at set point (available on set point ramping)

Digital input: 4 input for set point selection, PID parameter selection, AUTO/MAN switching, Remote /Local switching, or RUN/STOP switching, Non-voltage contact input 15VDC 1mA

Memory backup: Non-volatile RAM(Fe-RAM)

Interface: 300~9600 bps, ZE7101A0110 and ZE7101B0408 allow direct connection of RS-232C and RS-422A (RS-485) to the controller respectively

Power Supply: Voltage rating at 100 to 240VAC, 50/60Hz

Power consumption: Approx. 6VA/100VAC, 10VA/200VAC

Mass: Approx. 450g

Operating temperature range: -10 ~ 55°C

PERFORMANCE

Accuracy: $\pm (0.25\% + 1 \text{ digit})$ max., refer to Range Accuracy Table

Source impedance effects: Approx. $0.13\mu\text{V}/\Omega$ at TC & mV ranges, RTD lead wire 5Ω max.

Input impedance: Approx. $250\Omega/4\sim 20\text{mA}$, Approx. $500\text{k}\Omega/\text{Volt}$ input

CMRR: 140dB min.

NMRR: 60dB min.

OPTION

Analog retransmission: 0 ~ 20mA or 4~20 mA selectable for process variable, set point or output, accuracy $\pm 0.25\%$, resolution 0.05% max., load 600Ω max.

Isolated remote set point: 1~5 VDC or 0 ~ 5VDC, Approx. $500\text{k}\Omega$ input impedance

RANGE TABLE

INPUT	CODE	RANGE
B	b	0 ~ 1820°C
R	r1	0 ~ 1760°C
R	r2	0 ~ 1200°C
S	S	0 ~ 1760°C
K	k1	-200 ~ 1370°C
K	k2	0.0 ~ 600.0°C
K	k3	-199.9 ~ 300.0°C
E	E	-199.9 ~ 700.0°C
J	J1	-199.9 ~ 900.0°C
J	J2	-199.9 ~ 400.0°C
T	t	-199.9 ~ 400.0°C
W Re5-26	C	0 ~ 2320°C
N	n	0 ~ 1300°C
PR40-20	Pr	0 ~ 1880°C
PLII	PL	0 ~ 1390°C
U	U	-199.9 ~ 400.0°C
L	L	-199.9 ~ 900.0°C
Au-Fe	AUFE	0.0 ~ 300.0K
mV	10	0.0 ~ $\pm 10.0\text{mV}$
mV	20	0.0 ~ 20.0mV
mV	50	0.0 ~ 50.0mV
V	1-5	1.0 ~ 5.0V
V	0-5	0.0 ~ 5.0V
V	0-10	0.0 ~ 10.0V
mA	mA	4.0 ~ 20.0mA
Pt100	Pt0	-199.9 ~ 850.0°C
Pt100	Pt1	-199.9 ~ 300.0°C
Pt100	Pt2	-150.0 ~ 150.0°C
JPt100	JPt0	-199.9 ~ 650.0°C
JPt100	JPt1	-199.9 ~ 300.0°C
JPt100	JPt2	-150.0 ~ 150.0°C

RANGE AND ACCURACY TABLE

INPUT	CODE	ACCURACY	REMARKS
B	b *1		*1
R	r1 *2		0 ~ 400°C $\pm 5\%$
R	r2 *2		400 ~ 800°C $\pm (0.35\% + 1 \text{ digit})$
S	S *2		
K	k1		*2
K	k2	$\pm (0.25\% + 1 \text{ digit})$,	0 ~ 200°C $\pm (0.35\% + 1 \text{ digit})$
K	k3	$\pm (0.3\% + 1 \text{ digit})$,	
E	E	with in -200 to 0°C	*3
J	J1		0 ~ 20K $\pm (0.8\% + 1 \text{ digit})$
J	J2		20 ~ 50K $\pm (0.5\% + 1 \text{ digit})$
T	t		*4
WRe5-26	C		0 ~ 300°C $\pm (2\% + 1 \text{ digit})$
N	n		300 ~ 800°C $\pm (0.8\% + 1 \text{ digit})$
PLII	PL		
U	U		
L	L		
Au-Fe	AUFE *3	$\pm (0.5\% + 1 \text{ digit})$	
PR40-20	Pr *4		
Pt100	Pt0 JPt0	$\pm (0.25\% + 1 \text{ digit})$	
JPt100	Pt1 JPt1		
	Pt2 JPt2	$\pm (0.35\% + 1 \text{ digit})$	

Reference-junction compensation error:

$\pm 1^\circ\text{C}$ (15 ~ 35°C)

$\pm 1.5^\circ\text{C}$ (0 ~ 15°C, 35 ~ 55°C)

$\pm 2^\circ\text{C}$ (-10 ~ 0°C)

PART NAMES AND FUNCTIONS

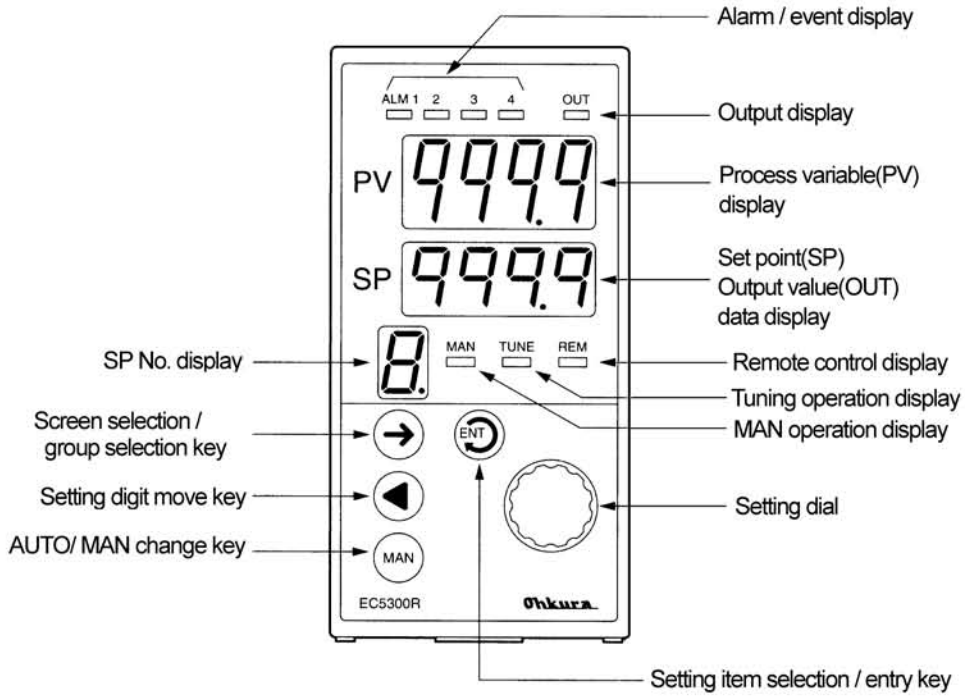

MODEL CODE NUMBER

EC530 ^①□ R ^②□ ^③□ 0 ^④□ ^⑤□

① 1st output (*)

1	Relay
2	SSR drive
3	—
4	—
5	4 ~ 20mA
6	0 ~ 5mA
7	—
8	Multi (Relay, SSR drive, 4 ~ 20mA)

② Event relay output

0	2 points
1	4 points

③ Built-in option

0	None
2	Isolated REM SP
5	AO (mA)
6	AO (mA), Isolated REM SP

⑤ Special

0	None
Z	Special

④ 2nd output (*)

0	None
1	Relay
2	SSR drive
3	—
4	—
5	4 ~ 20mA
6	0 ~ 5mA

*Designating 1st output, 2nd output

Output type	1st output	2nd output
Single output multi	8	0
Single output 0 ~ 5mA	6	0
Dual output	One of 1, 2, 5 and 6	One of 1, 2, 5 and 6

DEFAULT SETTINGS

Default setting at the shipment from the factory.

	Function	Initial value
Display / Input	Input range, scale	k1, -200 ~ 1370°C
	PV abnormal high limit value	1401°C
	PV abnormal low limit value	-231°C
	Key lock	OFF
	Sensor correction	0.0°C
	First order lag filter	0 seconds
	Number of moving average	8 times
Control	Control mode	PID control
	Direct / reverse action	Reverse action
	Preset output	OFF
	PV start	OFF
Alarm	Alarm1	Deviation High limit alarm : 1570°C
	Alarm2	Deviation Low limit alarm : -1570°C
	Alarm3 (only display at standard)	Deviation absolute value alarm : 1570°C
	Alarm4 (only display at standard)	Fail output
	Pause alarm	OFF
	Hysteresis width	0°C
	ON delay timer	0 seconds
Digital input	DI assignment	All points SP/PID change
	DI function	SP change
communication	Communication select	Original
	Transmission speed	9600bps
	Address	0

TERMINAL CONFIGURATION

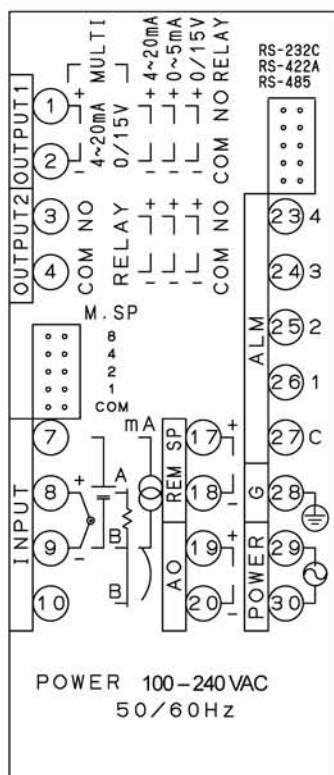

Some terminals do not function according as the model.

DIMENSIONS

(Unit: mm)

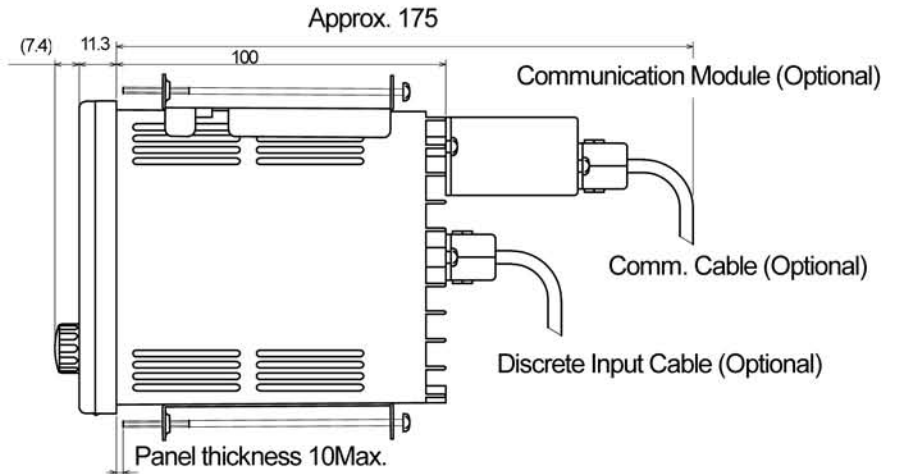
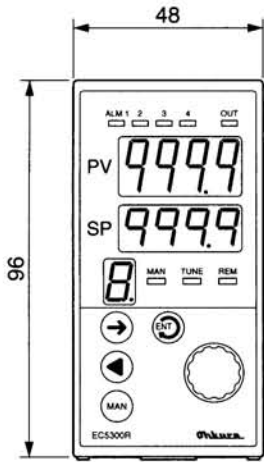

PANEL CUTOUT

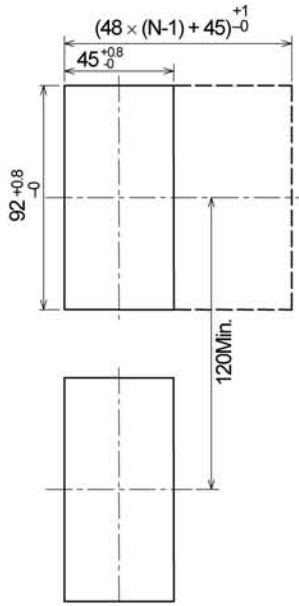

When mounting N units

PERIPHERAL UNIT

● Communication module

Item	Type	Model	Remarks
1	RS-232C	ZE7101A0110	
2	RS-422A/RS-485	ZE7101B0408	Terminal block type Up to 31 sets can be connected to Host

RS-232C Module
(Units : mm)

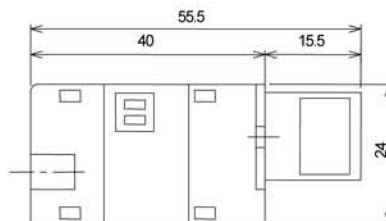
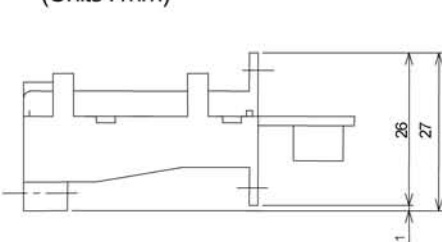

RS-422A/RS-485 Module
(Units : mm)

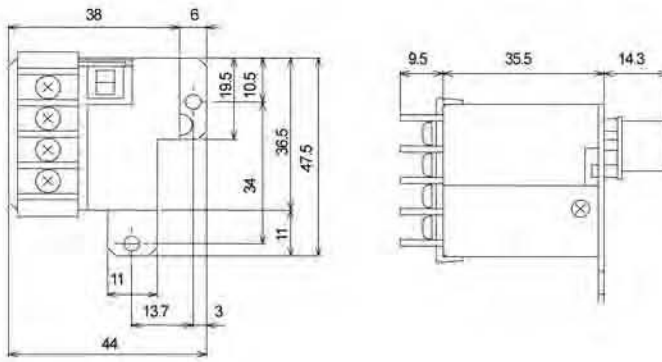

●Communication Cable

- RS-232C : Model :HMSU2255B02 Cable for EC5300R use, Length 2m with D – sub connector (male)
- RS-422A : Model :WMSU0075A01
- RS-485 : Model :WMSU0075A02

●Multi-Set point Selector

Model : ZE3301

Output: Binary and decimal code

Binary for EC5300R multi set point input

Decimal for customer instrument

Output contact rating: 30VDC, 1A, 1VA max.

Cable: HMSU2695A01, 1m
HMSU2695A02, 5m

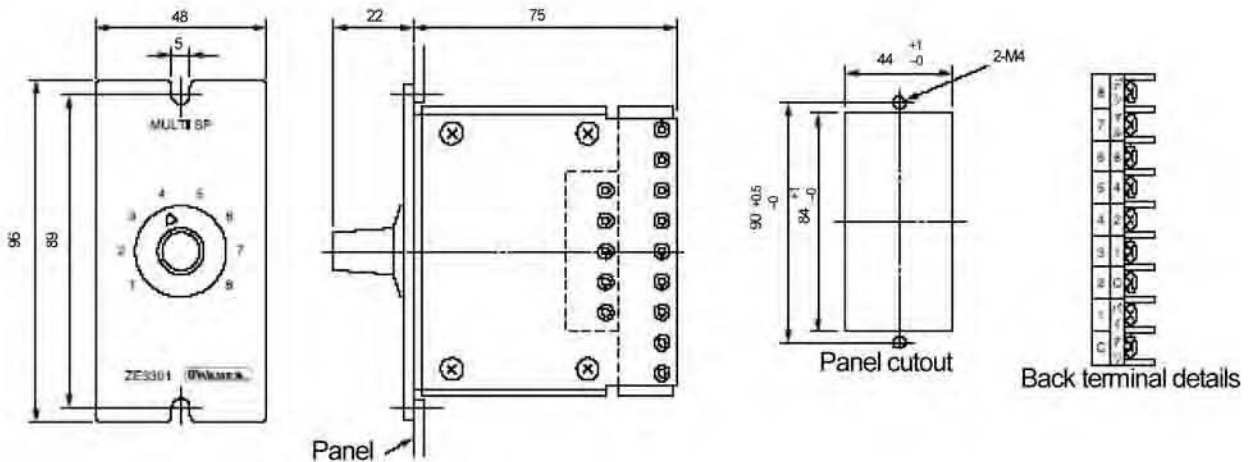

●External Resistor

Model : HMSU3081A02

Resistance : 250Ω ± 0.1%

 **CAUTION**

Do not install this device before consulting instruction manual

Specifications are subject to change without notice.

For further information, a quotation or a demonstration please contact to:

[Empty rectangular box for contact information]